

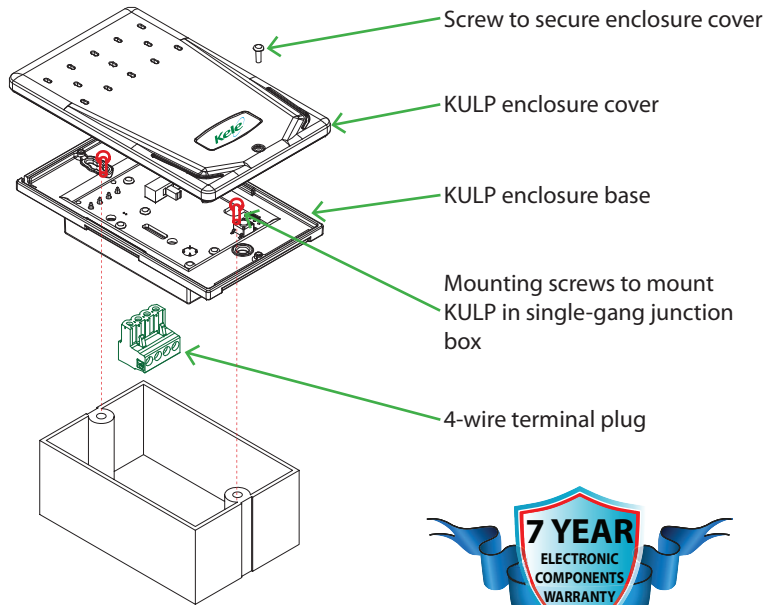

# KULP Wiring and Calibration Instructions



Junction box depicted is for illustration purposes: not included with sensor.

## Wiring Diagram

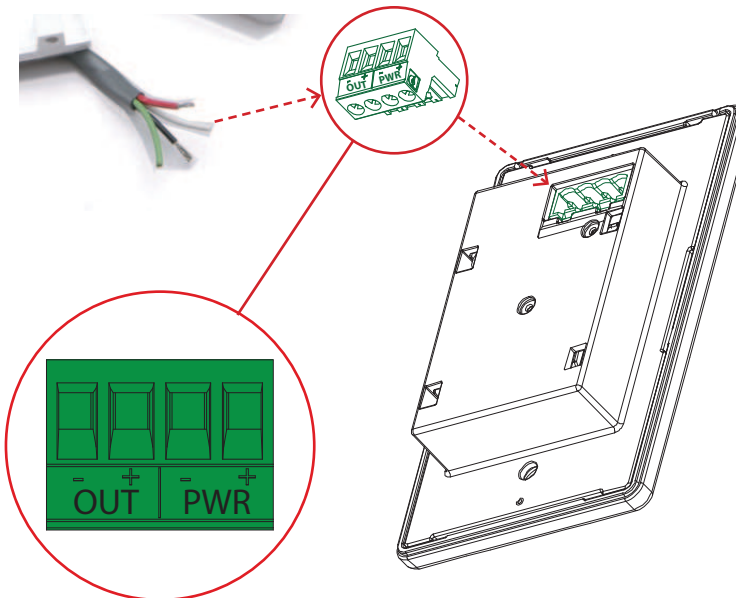

Wiring connections nomenclated on terminal block!

## Field-selectable output setting

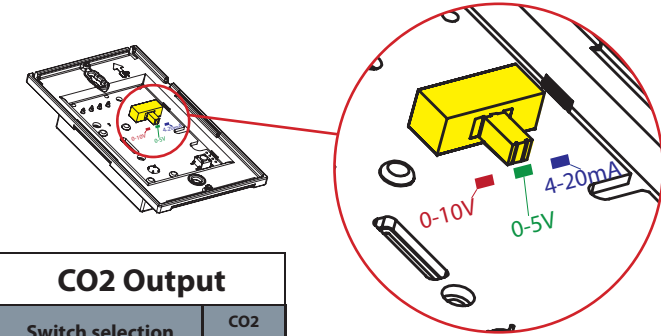

CO2 Output		
Switch selection		CO2 ppm
Current Output (4-20 mA)	4 mA	0
	12 mA	1,000
	20 mA	2,000
Voltage Output 0-10V	0 Volts	0
	5 Volts	1,000
	10 Volts	2,000
Voltage Output 0-5V	0 Volts	0
	2.5 Volts	1,000
	5 Volts	2,000

### Selectable Output Setting

Use switch to select between 3 different outputs

- 4-20 mA output -  $R_{LOOP} < 600 \Omega$
- 0-10 V output } Minimum input resistance 10K  $\Omega$
- 0-5 V output }

### "Ready to go" installation kit includes:

- Nomenclated terminal plug
- 6-32 x 1" machine screws (2)
- #2 self-tapping screw, white

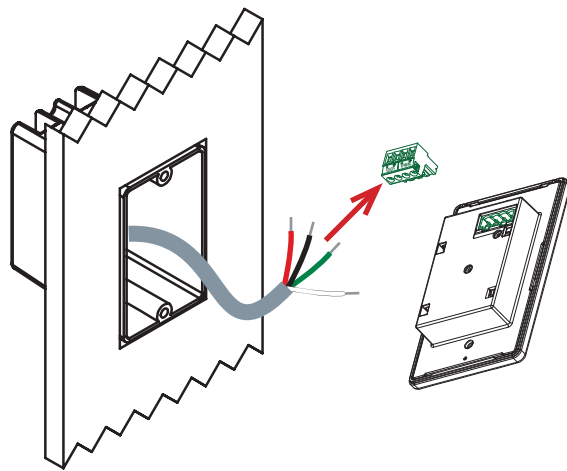

- 1**
- Install standard single gang junction box
  - Connect wires to terminal plug
  - Insert terminal plug into mating header on the back of the Kele KULP

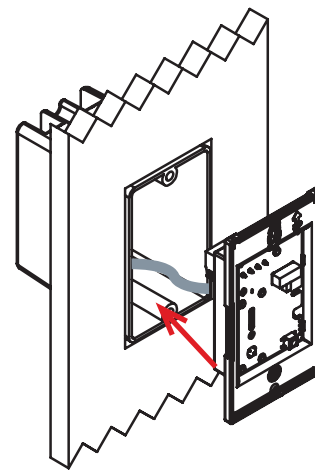

- 2**
- Insert Kele KULP CO2 sensor into junction box

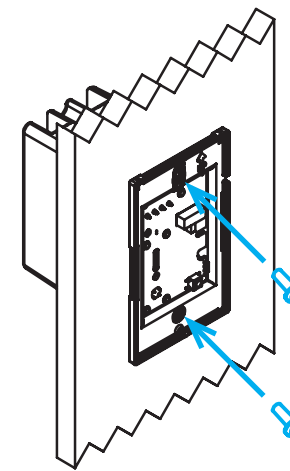

- 3**
- Install 2 mounting screws

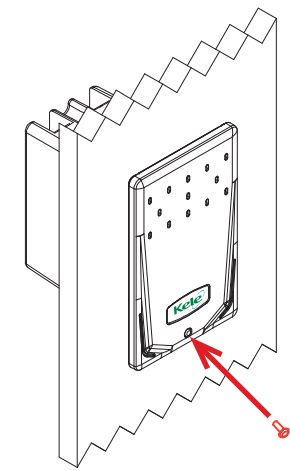

- 4**
- Snap on cover and install screw to secure enclosure cover
  - Installation complete!

Proudly



MADE IN USA

## Calibration-Kit

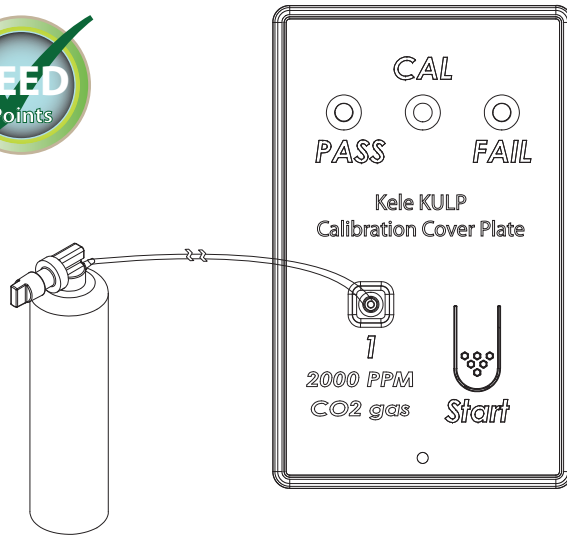

Your sensor comes factory-calibrated and does not need to be calibrated upon initial installation. Calibration kits are available and include all the necessary elements, including a 17 liter cylinder of 2000 PPM calibration gas (enough gas to calibrate 15-20 units). Recommended calibration interval is 5 years.

## CO2 Calibration Procedure

### Calibration Process: using the KULP-CAL kit

1. Remove the KULP cover plate and install the Calibration Cover Plate.
2. Attach the clear CO2 calibration gas tube onto the fitting marked "1".
3. Open the valve on the 2000 ppm CO2 bottle.
4. For best accuracy, allow calibration gas to flow for 15 seconds to fill the sensing cell, then press and hold the (START) button for 3 seconds to activate the calibration sequence (until the yellow LED begins to blink).
5. The yellow (CAL) LED will flash for 2 minutes to allow the reading to settle. During that time:
  - Do not remove electrical power during calibration. If power is lost no changes will be saved and the sensor will revert to using the previous calibration values.
  - Do not interrupt flow of the 2000 ppm CO2 gas.
  - The procedure can be aborted by pressing the START button.
6. At the end of the settling period, one of the following will occur:
  - The green (PASS) LED will flash continuously to indicate calibration was successful. In this case, press the (START) button within 3 minutes to save the new calibration to memory.
  - The red (FAIL) LED will flash continuously to indicate that the calibration failed due to an unstable measurement. In this case, press the (START) button to acknowledge that calibration was not successful and begin again with Step 4 above.
7. After calibration, the sensor will return to normal operation.
8. Close the valve on the 2000 ppm CO2 bottle, and remove the tubing.
9. Remove the Calibration Cover Plate and reinstall the KULP enclosure cover.
10. Reinstall the enclosure cover locking screw.

## CO2 Calibration Indicator LEDs

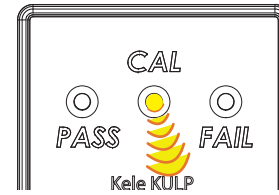

When calibration sequence is activated, "CAL" LED will blink yellow.



Green LED will blink if the unit "PASSES" calibration.

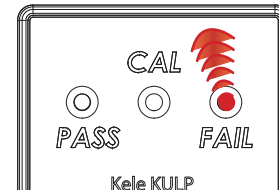

Red LED will blink if the unit "FAILS" calibration.

### CARBON DIOXIDE SENSOR (CO2)

Parameter	Value
Operating Principle	Non-dispersive infrared (NDIR)
Gas Sampling Method	Diffusion
Measurement Range	0-2000 ppm (Other ranges available by request)
Repeatability	± 20 ppm CO2
Measurement Accuracy	± 30 ppm ± 2% of reading
Recommended Calibration Interval	5 years
Warm Up Time	Less than 1 minute
Calibration	"ONE POINT" single-button calibration with Kele Calibration Kit (PATENTED)
Warranty	7 years electronic components/ 3 years NDIR Sensor

### Overall Specification

Parameter	Value	
Power Requirements	18 - 30 VDC or 18 - 28 Vrms AC	
Power Consumption	2.5 VA	
Operating Temperature Range	0 - 50 °C	
Operating Humidity Range	0 - 99% RH, non-condensing	
Output (for details see "field-selectable output setting diagram" page 1)	Current Output	4-20 mA
	Voltage Output	0-10V
	Voltage Output	0-5V
Optional Current Output (linear)	4-20 mA $R_{LOOP} < 600 \Omega$	
Storage Temperature	-10 to 60 °C	
Dimensions	2.80" W x 4.57" H x .27" T	
Enclosure Material	UV and UL 94V-0 Fire Resistant ABS Plastic	
Weight	5.85 oz (0.17 kg)	



3300 Brother Boulevard Memphis, TN 38133 USA: 877-826-9045 Fax: 800-284-5353 <https://www.kele.com>



REV6 9/2018